

PART No: 05012
PRODUCT: Brake Controller Harness Installation Instructions
UNIVERSAL FITMENT

INSTALLATION INSTRUCTIONS

Please ensure that these instructions are understood prior to fitment.
NOTE: Individual vehicles may differ. Please refer to vehicle specific fitting instructions where available.

For vehicle specific instructions, visit
www.haymanreese.com.au/wiringinstructions.

Brake Controller Harness
Installation Instructions

UNIVERSAL FITMENT

Part No: 05012

Compatible with 7-pin and 12-pin Trailer Socket

PART No: 05012
PRODUCT: Brake Controller Harness Installation Instructions
UNIVERSAL FITMENT

INSTALLATION INSTRUCTIONS

Please ensure that these instructions are understood prior to fitment.
NOTE: Individual vehicles may differ. Please refer to vehicle specific fitting instructions where available.

For vehicle specific instructions, visit
www.haymanreese.com.au/wiringinstructions.

TYPICAL VEHICLE HARNESS LAYOUT

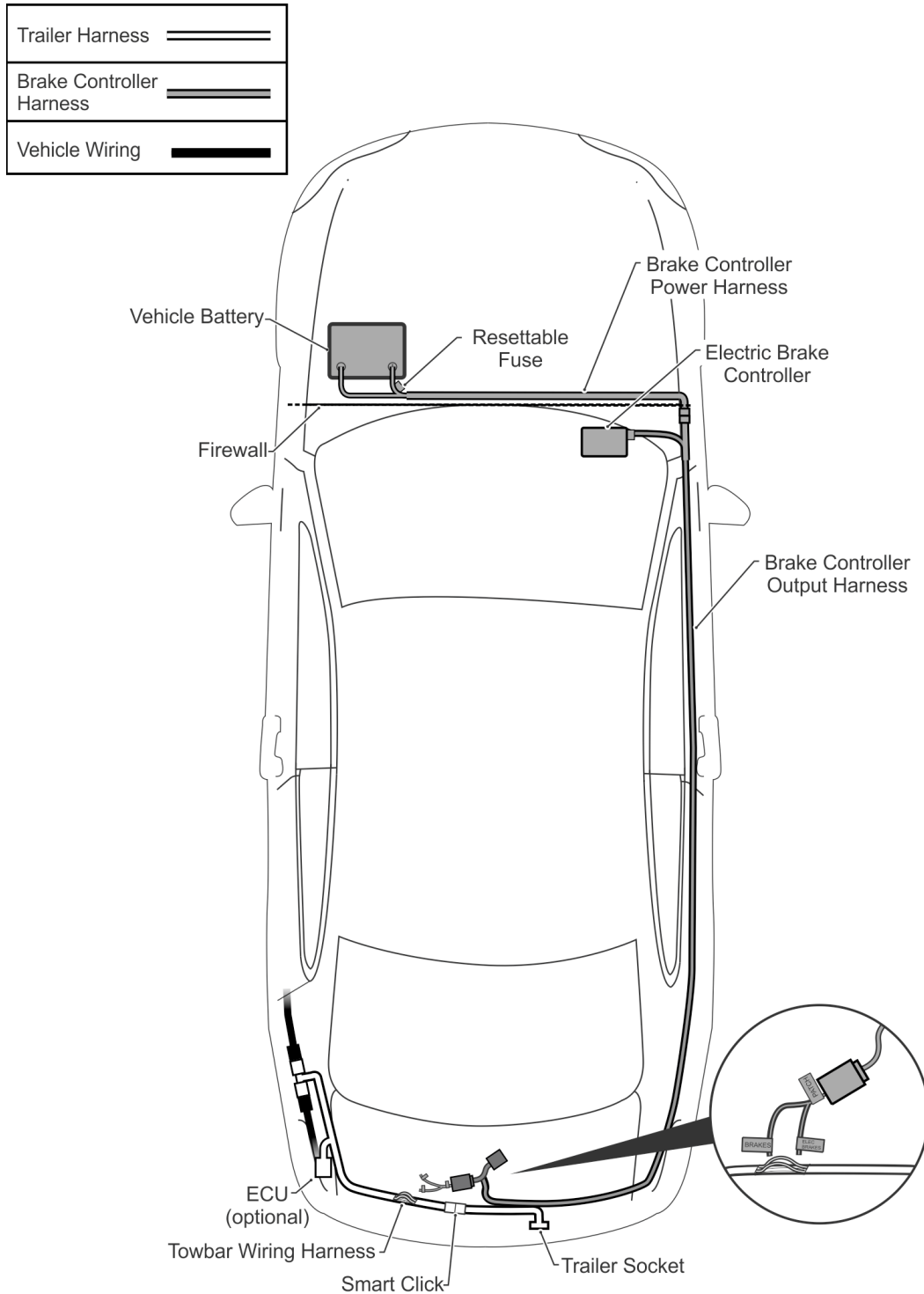

Part No: 05012
Brake Controller Harness Standard

PART No: 05012
PRODUCT: Brake Controller Harness Installation Instructions
UNIVERSAL FITMENT

INSTALLATION INSTRUCTIONS

Please ensure that these instructions are understood prior to fitment.

NOTE: Individual vehicles may differ. Please refer to vehicle specific fitting instructions where available.

For vehicle specific instructions, visit
www.haymanreese.com.au/wiringinstructions.

Important 	When routing any Harnesses, ensure you avoid any sources of heat, sharp edges and moving parts and secure at every 200mm intervals.
---	---

1. Locate the vehicle battery. **Note: Do not connect the harness to the battery at this point.**
2. Route the power input harness through a vacant grommet hole and into the vehicle cabin. **Note: If a suitable grommet hole cannot be found drill a Ø25mm hole in the vehicle firewall. File any rough or sharp edges and apply rust inhibitor. Spray the supplied grommet with a CRC or WD/40 and slide the grommet over the corrugated tube. Secure in place with a cable tie (not supplied). Ensure the harness is away from sharp edges, moving parts and hot surfaces.**
3. Inside the vehicle cabin, following the diagram below, locate the ORANGE power female terminal (1) and the WHITE ground female terminal (2) to the locations as shown on the 2-way connector (3). House the power & ground input harness female terminals (1 & 2) into the mating connector (3) as per diagram below. Connect the power input harness connector (3) to the body harness mating connector, an audible click can be heard when correctly installed.

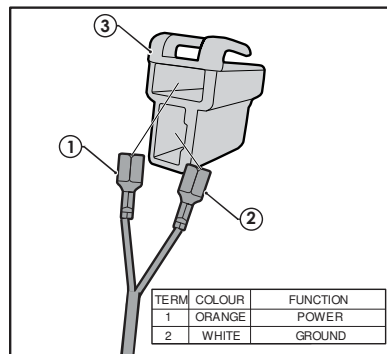

4. Remove the driver side lower dash garnish, ensure any fasteners are removed.
5. Locate the electric brake controller and mount the electric brake controller mounting bracket.
6. Route the brake controller power harness towards the electric brake controller mounting location. Secure the brake controller harness with cable ties (not supplied) away from any moving parts, sharp edges or hot surfaces at 200mm intervals.

PART No: 05012
PRODUCT: Brake Controller Harness Installation Instructions
UNIVERSAL FITMENT

INSTALLATION INSTRUCTIONS

Please ensure that these instructions are understood prior to fitment.

NOTE: Individual vehicles may differ. Please refer to vehicle specific fitting instructions where available.

For vehicle specific instructions, visit
www.haymanreese.com.au/wiringinstructions.

- Following the diagram below, house the brake controller power harness terminals (1) to the corresponding slot on the connector (2).
- Insert the secondary lock (3) into the connector (2). Connect the brake controller power harness connector to the brake controller output harness.

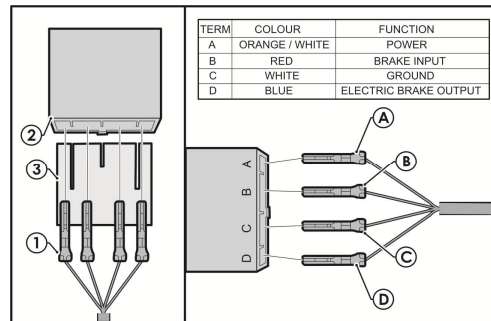

- Route the brake output harness towards the rear of the vehicle. Secure the brake controller harness with cable ties (not supplied) away from any moving parts, sharp edges or hot surfaces at 200mm intervals.
- Locate the towbar wiring harness.
- If fitting onto a vehicle with a Smart Click Harness installed (can be identified with a blue connector on the towbar wiring harness), continue with Step 12. If not installed with Smart Click, go to Step 13.**
- Disconnect and discard the female blue 8-way tail patch connector containing the 'brakes signal' and 'electric brakes' labels. Connect the brake controller harness 8-way connector to the towbar wiring harness mating connector. Connect the brake output harness 8-way connector to the tail harness 8-way mating connector. Push the connectors in until a click is heard. **Go to Step 14.**

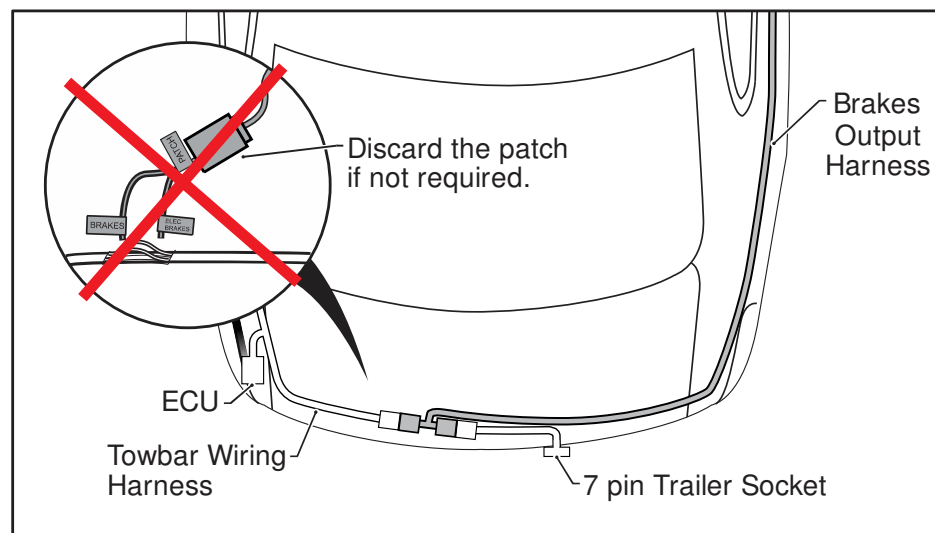

PART No: 05012
PRODUCT: Brake Controller Harness Installation Instructions
UNIVERSAL FITMENT

INSTALLATION INSTRUCTIONS

Please ensure that these instructions are understood prior to fitment.

NOTE: Individual vehicles may differ. Please refer to vehicle specific fitting instructions where available.

For vehicle specific instructions, visit
www.haymanreese.com.au/wiringinstructions.

13. At the rear of the vehicle, source the brakes signal and electric brakes from the towbar wiring harness and splice the appropriate wires together as marked on the patch harness.

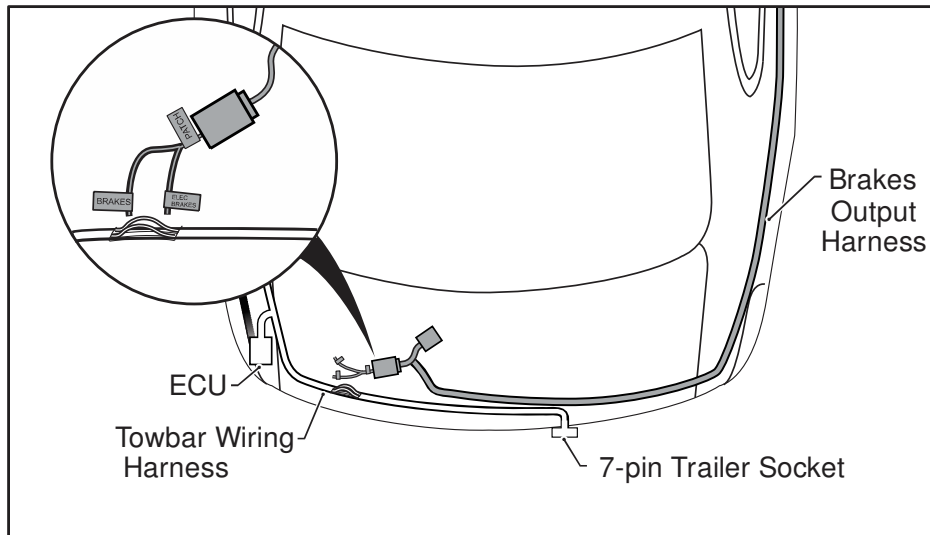

14. Connect the brake controller power harness **ORANGE / WHITE** wire to the positive terminal on the vehicle battery.
15. Connect the brake controller power harness **WHITE** wire to the negative terminal on the vehicle battery. Secure the brake controller harness with cable ties (not supplied) away from any moving parts, sharp edges or hot surfaces at 200mm intervals.
16. Test the electric brake controller function using a light board or multimeter.
17. Secure the brake controller harness with cable ties (not supplied) away from any moving parts, sharp edges or hot surfaces at 200mm intervals.
18. Re-fit all removed parts and secure all fasteners, ensuring there are no squeaks or rattles.
19. Place the instructions in the glove box after fitment.